

AED9101C

Basic device for
AD103C

AED9101C
Basic device



AD103C
Amplifier board

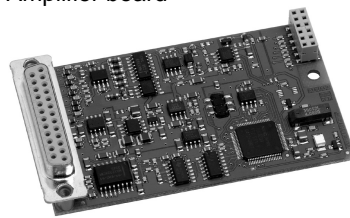

Special features

- For static and dynamic applications
- RS-232, RS-422 or RS-485 interfaces
- Test report for 10 000 digits class III available
- Trigger input
- 6...30 V Supply voltage range
- Degree of protection IP65
- EMC protection
- Diagnostics bus for analyzing and additional indication

Dimensions (in mm; 1 mm= 0.03937 inches)

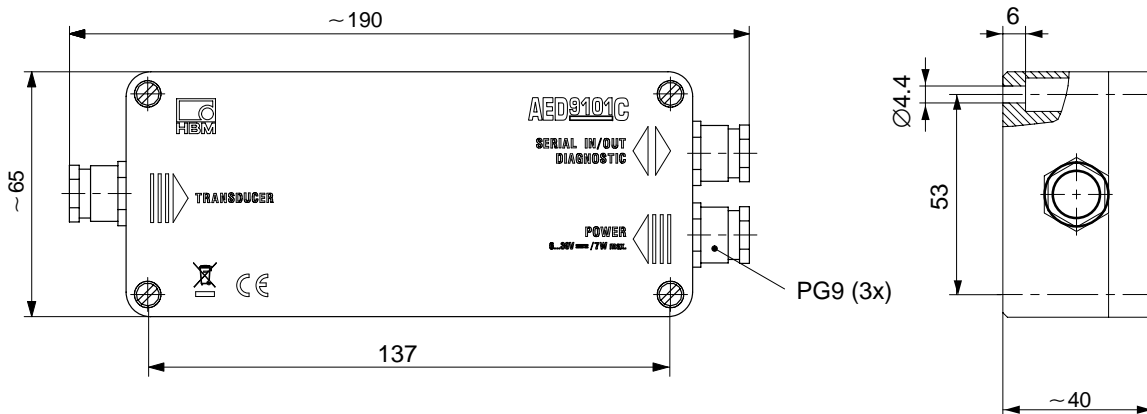

Specifications

Type		AED9101C
Measuring amplifier		AD103C
Measuring signal input	mV/V	±3, nominal ±2
Transducer connection:		
Strain gage transducer (full bridge)	Ω	≥40...4000
Transducer connection		6-wire circuit
Transducer cable length	m	≤100
Bridge excitation voltage	V _{DC}	5
Interfaces:		
Hardware (selectable via slide switch)		RS-232, RS-422, RS-485
Interface cable length RS-232	m	≤15
Interface cable length RS-422, RS-485	m	≤1000
Max. number of bus members		32
Diagnostics bus:		
Protocol		ASCII/Binary
Baud rate, max.	kbit/s	38.4
Node address		0 ... 89
Length of Interface cable, max	m	1000
Trigger input		
Input voltage range, LOW	V	0...1
Input voltage range, HIGH	V	2...30
Input current at High level = 30 V	mA	< 3
Supply:		
Supply voltage	V _{DC}	6 ... 30
Current consumption (without load cell)	mA	≤ 120 ¹⁾
Temperature range:		
Nominal temperature	°C [°F]	-10...+40 [+14...+104]
Operating temperature		-20...+60 [-4...+140]
Storage temperature		-25...+85 [-13...+185]
Dimensions	mm	190 x 65 x 40
Weight, approx.	g	440 (without AD10x)
Degree of protection according to EN60529 (IEC 529)		IP65

$$1) \text{ Current consumption} = \leq 120 \text{ mA} + \frac{\text{Supply voltage } U_B = 5 \text{ V}}{\text{Bridge resistance } R_B}$$

Order designations:

1-AED9101C = Basic device **AED9101C**

1-AD103C = Amplifier PCB **AD103C** (see separate Data sheet)

Accessories, to be ordered separately

Legal-for-trade digital scale display (see separate Data sheet)

1-DWS2103

Documentation

1-FIT-AED-DOC = (CD-ROM with operating manual and AED_Panel32 panel program)

© Hottinger Baldwin Messtechnik GmbH.
 Modifications reserved. All details describe our products in general form only. They are not to be understood as express warranty and do not constitute any liability whatsoever.

Hottinger Baldwin Messtechnik GmbH

Im Tiefen See 45 · 64293 Darmstadt · Germany
 Tel. +49 6151 803-0 · Fax: +49 6151 803-9100
 Email: info@hbm.com · www.hbm.com



measure and predict with confidence